



ACCESSORIES

tester 1006

TESTER 1006

For the simultaneous control of up to 4 load cells in any weighing system

Functioning as a calibrator and a peak detector

Upload and download function for programming tools DAT and MC 302 series

For the correct mechanical installation and fault diagnosis

Standard delivered with cable for connection to our junction boxes / sum mod. CEM 4/C and GCS 4/C

The simultaneous display of the signal of each load cell allows to control the entire weighing system, weight distribution, overloading, faulty cells or faulty connections

TECHNICAL CHARACTERISTICS TESTER 1006

Power transducers:	5 VDC / 60 mA (max 4 350 Ohm load cells in parallel)
Measuring range:	from -3.9 to +3.9 mV / V
Linearity:	<0.01% of full scale
Thermal drift:	<0.001% of full scale / °C
Display:	Graphical 3 "
A/D converter:	24 bits
Internal resolution:	> Of 16,000,000 points
Displayable Resolution:	50,000 divisions
Value division (selectable):	x1, x2, x5
Decimal set:	0,0 ; 0,00 ; 0,000
Keyboard:	16 keys + on/off
Power supply instrument:	4 AA batteries - Power consumption 5 W
Consumption:	125 ÷ 190 mA
Battery life:	about 4 hours with alkaline batteries, about 8 hours with rechargeable Ni-MH 1.2 V (2000 mAh)
Operating temperature:	-10 To +50 ° C (max 85% humidity non-condensing)
Storage Temperature:	-20 ÷ +70 °C
Degree of protection:	IP54
Weight:	500 g
Connections to the load cells:	25-pin D-sub connector and cable length 2m
Connections to the instruments:	25-pin D-sub connector and cable length 0.5 m

CALIBRATOR

Accuracy:	0.033% of F.S.
Voltage power cell:	3 to 12 VDC
Signal:	-3 ÷ +20.3 mV
Impedance:	Selectable 350/700 Ohms, or set 300 to 4500 Ohms





Display visualization

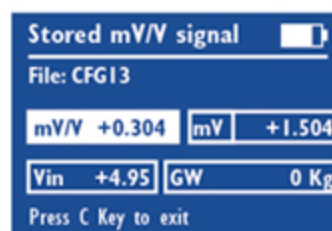
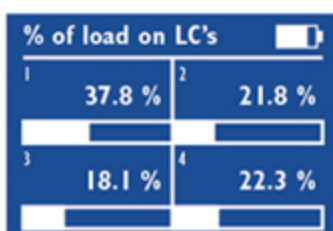
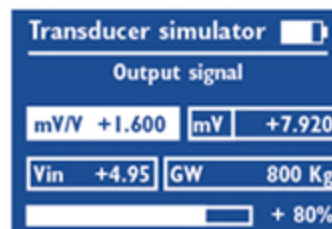
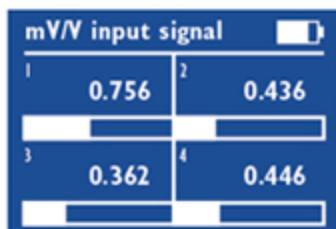



Pavone Sistemi
pesatura elettronica industriale

ACCESSORIES

tester 1006

TESTER 1006

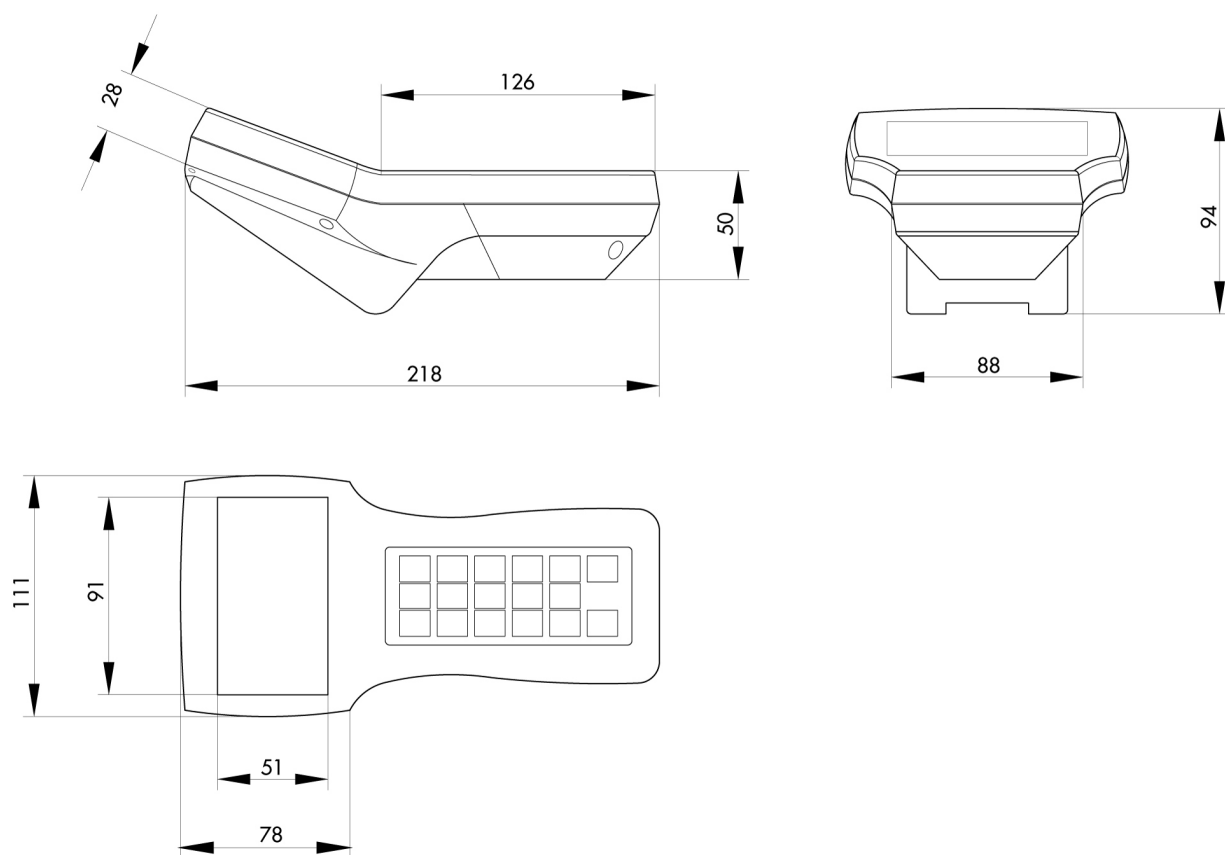

**SCIENCE
GATE**
Your Automation Partner



SCIGATE AUTOMATION (S) PTE LTD

No.1 Bukit Batok Street 22 #01-01 Singapore 659592

Tel: (65) 6561 0488

Fax: (65) 6562 0588

Email: sales@scigate.com.sg

Web: www.scigate.com.sg

Business Hours: Monday - Friday 8.30am - 6.15pm

